

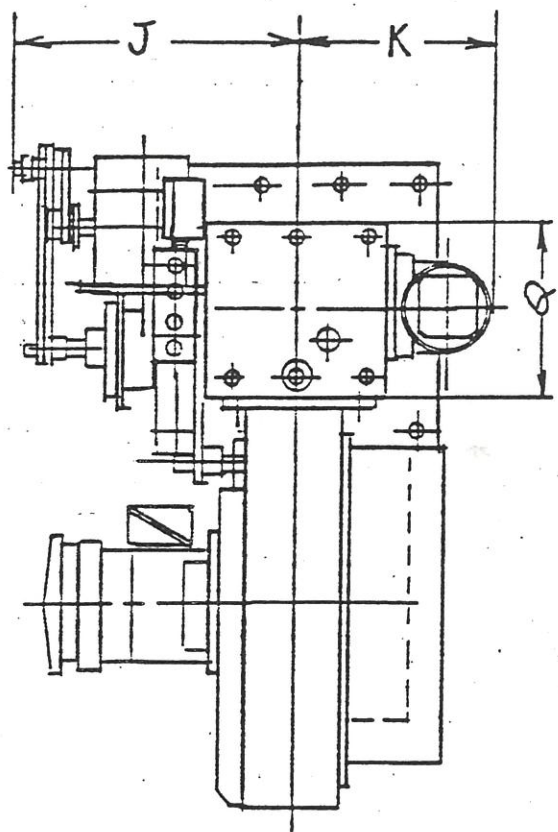

来	歴	年月日	
△		..	
△		..	

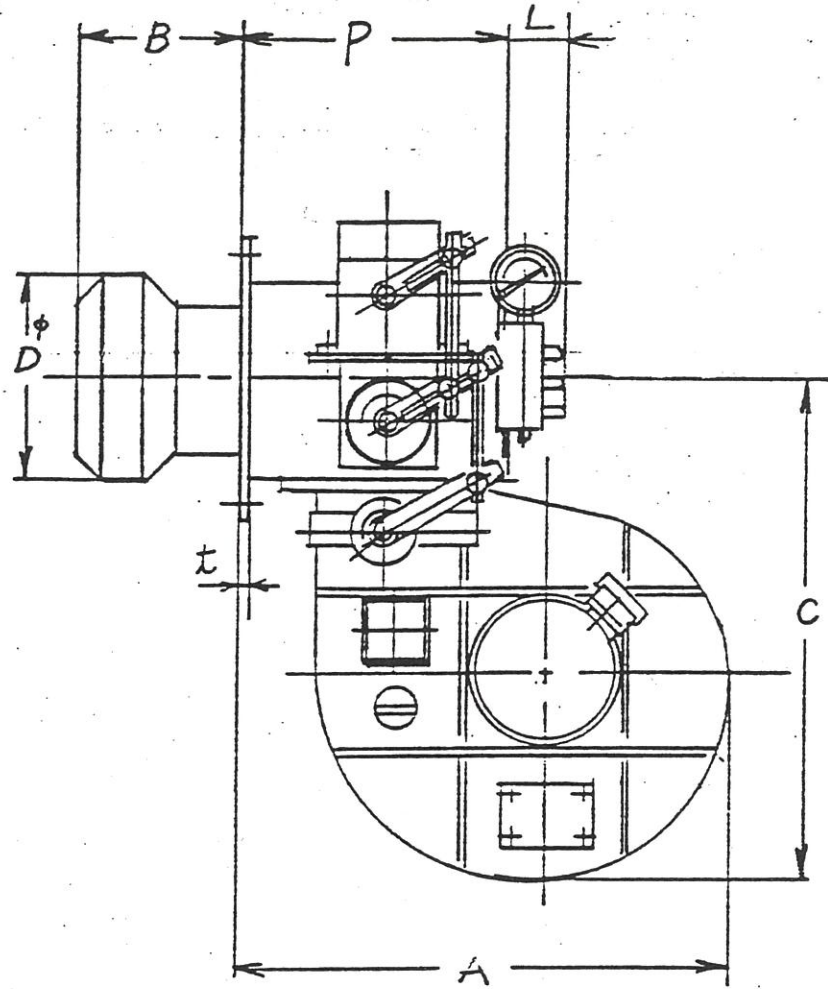
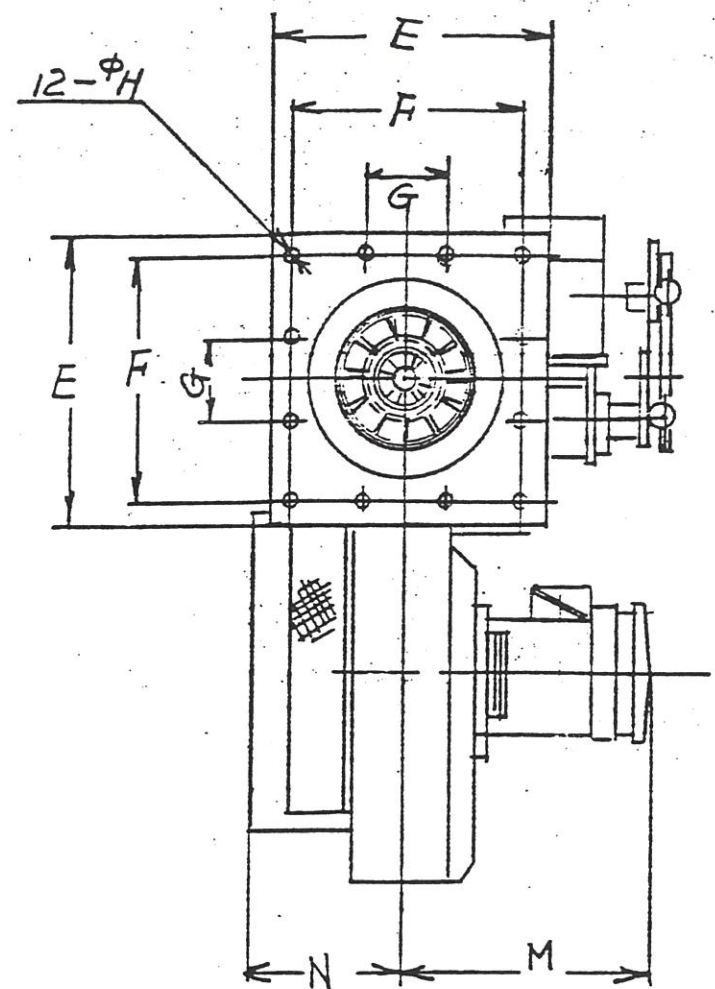

ハ-ナ型	A	B	C	D	E	F	G	H	J	K	L	M	N	P	Q	T
MGT-500	673	261	638	260	410	340	140	18	330	380	160	290	128	376	250	6
MGT-800	637	261	638	260	410	340	140	18	330	380	160	290	128	376	250	6
MGT-1000	742	270	716	270	410	340	140	18	360	420	180	342	330	459	300	6
MGT-1300	831	350	741	270	440	390	132	18	360	420	180	342	330	459	300	6
MGT-1700	845	320	749	320	440	390	132	18	360	420	180	417	300	459	300	6
MGT-2000	845	350	789	390	510	468	156	18	400	480	200	417	360	459	380	6
MGT-2500	845	350	789	390	510	468	156	18	400	480	200	417	360	459	380	6
MGT-3000	985	430	966	490	540	500	170	18	440	510	200	466	360	509	440	6

削り加工無記号公差	呼び寸法区分(mm)	寸法(mm)	符号	品名	材質	数量	記	事
1:1.1	1.1~1.5	±0.1	型番	MGT	名	コナ	称	メカ=カバ カバ=フ
1:1.2	1.6~2.5	±0.2						
1:1.3	2.6~4.0	±0.3	製図	検図	承認	作成	尺	度
1:1.4	4.1~6.3	±0.4	検図	林			図	
1:1.5	6.4~10.0	±0.5	承認				番	M-94031
1:1.6	10.1~16.0	±0.6	作成	Hb.J.4				
1:1.7	16.1~25.0	±0.8						
1:1.8	25.1~40.0	±1.0						
1:1.9	40.1~63.0	±1.5						
1:2.0	63.1~100.0	±2.0						
1:2.1	100.1~160.0	±2.5						
1:2.2	160.1~250.0	±3.0						
1:2.3	250.1~400.0	±4.0						
1:2.4	400.1~630.0	±5.0						
1:2.5	630.1~1000.0	±7.0						
1:2.6	1000.1~1600.0	±10.0						